

COUNTDOWN TIMER WITH MANUAL RELEASE AND ABORT SWITCHES

Replacement Parts

Part Number	Description
10-2977	Countdown Timer with Manual Release/Abort Switch Assembly
10-2978 ¹	Face Plate with Timer Assembly
10-2981 ¹	Abort Switch
10-2982 ¹	Manual Release Switch
02-16365 ^{2,3}	Contact Block, Normally Open (NO)
02-16366 ³	Contact Block, Normally Closed (NC)
02-16367 ²	Dummy Contact Block
02-2213 ²	Security Tie (beaded cable)
02-16376 ²	Safety Clip
02-2316 ^{2,3}	6/32 Mounting Screw
02-13170 ²	Key, #0
02-4780 ^{2,3}	Contact Block Adapter
02-16401 ^{2,3}	Anti-Rotation Ring
02-16402 ^{2,3}	Locking Lever Cap
02-12318	Locking Ring Wrench
02-16369 ⁴	30mm to 22mm Trim Ring
02-2273 ¹	6-Gang Masonry Box, RACO 960

¹Included in 10-2977 switch assembly.
²Included in 10-2982 switch assembly.
³Included in 10-2981 switch assembly.
⁴Allows 22mm switch to be mounted to a 30mm switch face plate.

Specifications

Operating Temperature:	0°C to 49°C (32°F to 120°F)
Operating Humidity:	93% RH, non-condensing
Weight:	.85 lbs. (385 grams)
Mounting:	6-gang masonry box (RACO 960) or equivalent. For indoor use only.
Counter Rating:	24VDC, 163 mA
Contact Block Rating:	30VDC @ 5 AMPS
Applicable Wire Size:	Minimum 1 x 22 AWG, max 2 x 14 AWG or 1 x 12 AWG
Approvals:	Underwriters Laboratories (UL) Factory Mutual (FM) California State Fire Marshal (CSFM)
Compliance:	Restriction of Hazardous Substances (RoHS)

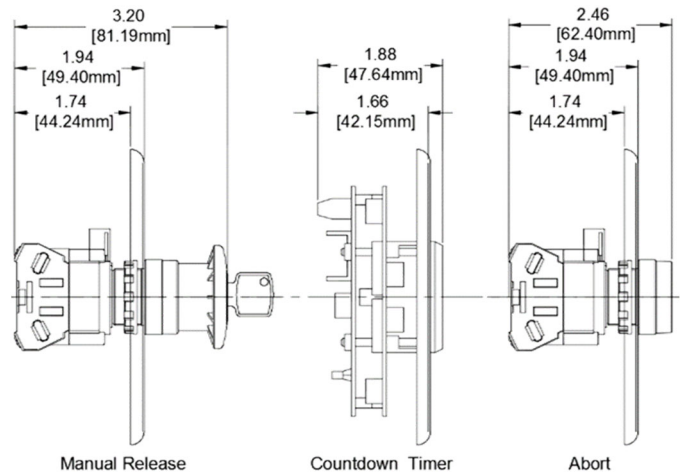

Switch Side Views

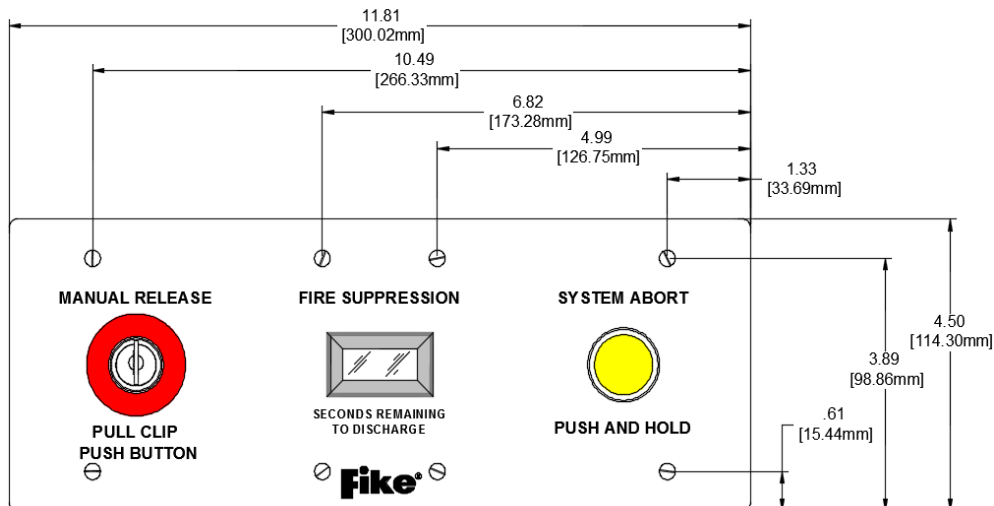

Switch Front View

Manual Release Switch Assembly

The manual release switch components are shipped disassembled and must be assembled prior to installation using the following instructions.

1. Remove the face plate with timer assembly from the anti-static packaging.

CAUTION: The countdown timer contains static sensitive components. Handle the timer by the edges only and avoid touching the integrated components. Always ground yourself before handling the countdown timer assembly.

2. Remove the protective plastic film from the stainless steel face plate.
3. Remove the locking ring from the switch operator.
4. Verify that the TOP mark on the operator and the triangle mark (▲) on the anti-rotation ring are alligned.
5. Insert the switch operator through the hole provided in the switch face plate making sure the TOP mark on the operator is facing up and is aligned with the anti-rotation notch provided in the face plate.
6. Install the locking ring onto the switch operator. Tighten using locking ring wrench. Do not over tighten if using pliers. Maximum torque should not exceed 2N-m (20.4 Kgf cm). Do not excessively tighten the locking ring.
7. Remove the locking lever cap from the contact block locking lever.
8. Turn the locking lever to the unlocked position.
9. Mount the contact block to the switch operator.
10. Turn the locking lever to the locked position.
11. Install the locking lever cap onto the locking lever.
12. Switch assembly is complete.

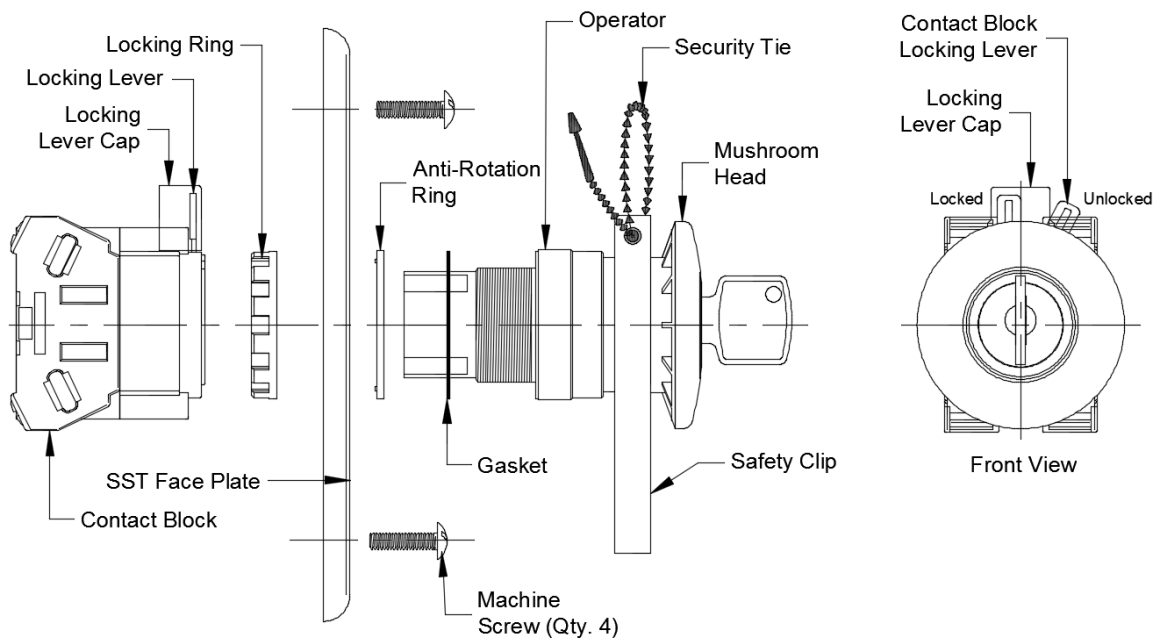

Switch Assembly

Abort Switch Assembly

The abort switch components are shipped disassembled and must be assembled prior to installation using the following instructions.

1. Remove the locking ring from the switch operator.
2. Verify that the TOP mark on the operator and the triangle mark (▲) on the anti-rotation ring are aligned.
3. Insert the switch operator through the hole provided in the switch face plate making sure the TOP mark on the operator is facing up and is aligned with the anti-rotation notch provided in the face plate.
4. Install the locking ring onto the switch operator. Tighten using locking ring wrench. Do not over tighten if using pliers. Maximum torque should not exceed 2N-m (20.4 Kgf cm). Do not excessively tighten the locking ring.
5. Remove the safety lever lock from the contact block locking lever.
6. Turn the locking lever to the unlocked position.
7. Mount the contact block to the switch operator.
8. Turn the locking lever to the locked position.
9. Install the locking lever cap onto the locking lever.
10. Switch assembly is complete.

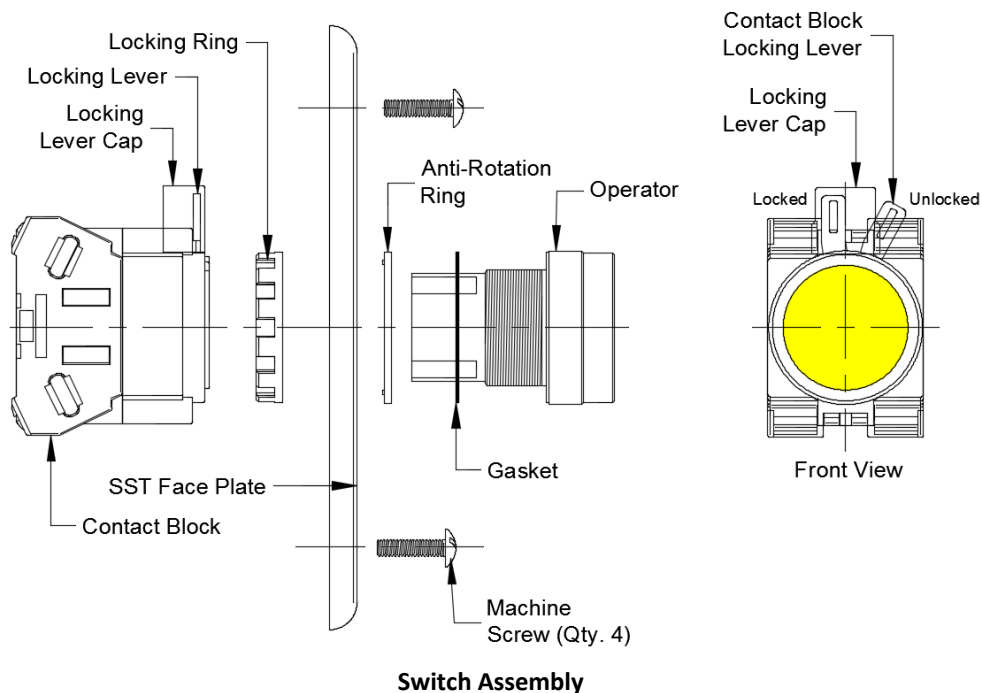

Set Countdown Timer

1. Set the timer's countdown time using the two rotary switches located on the backside of the assembly. The rotary switch on the right adds tens of seconds to the countdown time; whereas, the rotary switch on the left adds individual seconds to the countdown time. The settings for the two switches are added together for the final countdown time setting (0 to 99 seconds).

NOTE: The timer's countdown time must be set to match the control panel's Pre-discharge countdown time. By default, the countdown timer is set to 30 seconds when shipped from the factory.

Switch Assembly Installation

WARNING: If installing the switch in an operational system:

- 1) Disconnect the releasing mechanism from all suppression cylinders/containers prior to installation to prevent accidental system discharge.
- 2) Power down the system by removing all power sources feeding the control unit (AC and DC).

NOTE: The mounting location for the switch should be free from excessive vibration, dust, and moisture.

1. Install the electrical box (recess or surface mount).
2. Pull field wiring into electrical box.
3. Connect field wiring to switch contact blocks. Maximum 8mm (0.31 in.) recommended wire insulation stripping length.
4. Connect field wiring to timer terminals.
5. Reapply power to the system and test switch and timer operation prior to reconnecting releasing mechanism to all suppression cylinders/containers.
6. Make adjustments to the countdown timer settings (if necessary) so that the time displayed corresponds with the control panel's pre-discharge countdown time.
7. Secure stainless steel faceplate to mounting box with supplied machine screws.
8. Install the safety clip to the back of the manual release switch mushroom head.
9. Install beaded security tie through holes provided in safety clip. Pull tight making sure the safety clip is held firmly in place preventing the red mushroom head from being pressed without removal of the safety clip.
10. Store switch keys in a secure location.

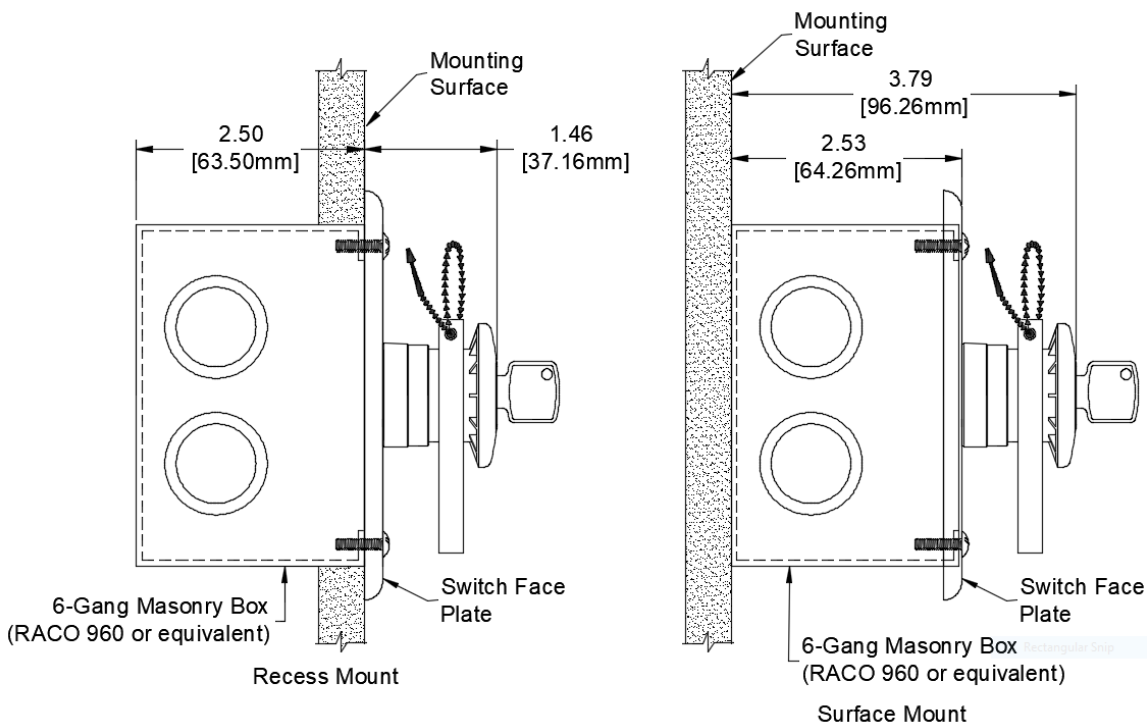

Switch Mounting

Switch Wiring

Note: Incoming and outgoing conductors must be separated at all terminal connections.

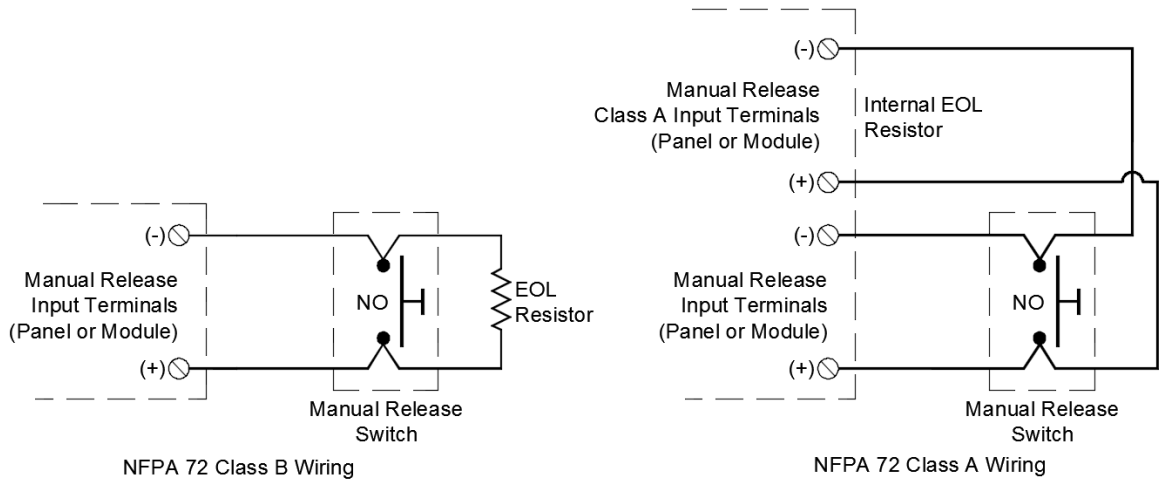

See Control Unit Manual for Specific Wiring Requirements.

Manual Release Switch Wiring

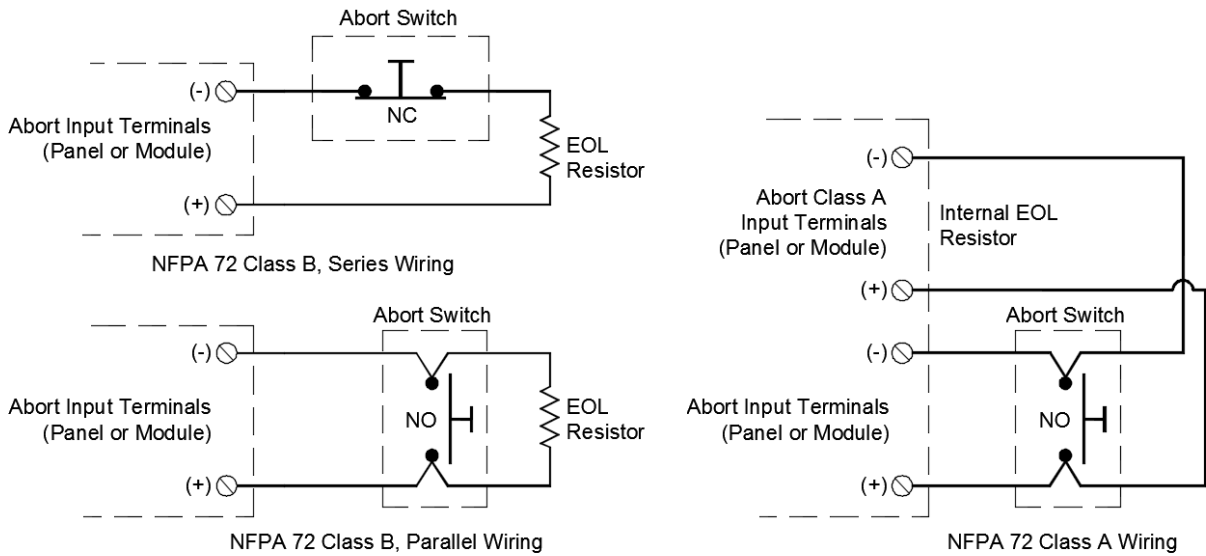

See Control Unit Manual for Specific Wiring Requirements.

Abort Switch Wiring

Countdown Timer Wiring

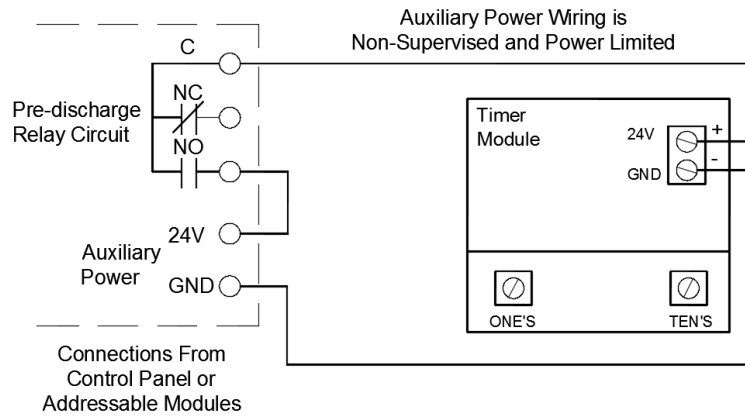

Typical Countdown Timer Wiring to Relay Output

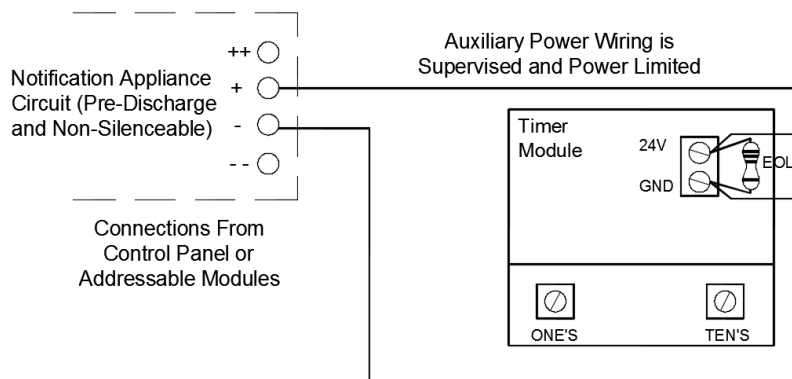

Typical Countdown Timer Wiring to Notification Appliance Circuit (Class B)

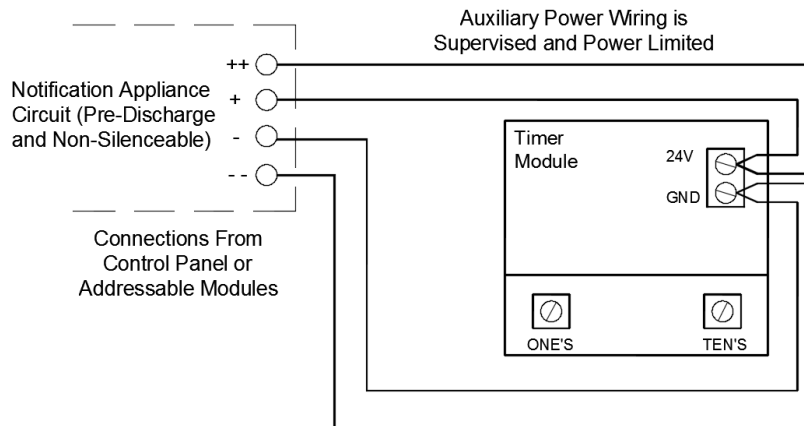

Typical Countdown Timer Wiring to Notification Appliance Circuit (Class A)